

MorphoAccess[®] SIGMA Series

Quick User Guide



All descriptions illustrations, and specifications in this brochure should be considered approximate and may relate to optional equipment or feature

This document and the information therein are the property of Morpho, They must not be copied or communicated to a third party without the prior written authorization of Morpho.

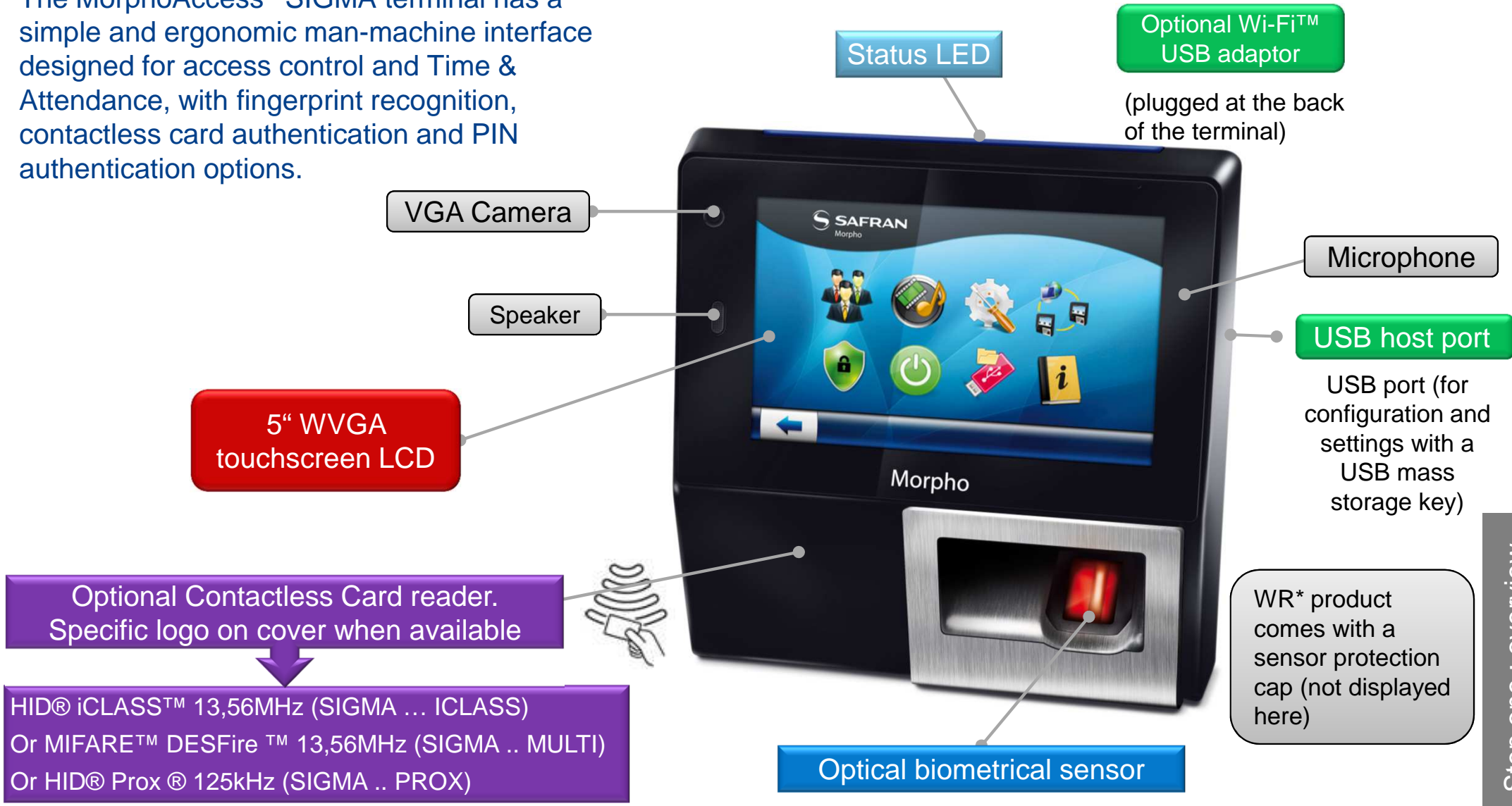

Table of Contents

Color	Step	Content
	One	Overview
	Two	Wiring
	Three	Communication
	Four	ACP or SDAC
	Five	Administration
	Six	Software
	Seven	Enrollment



MorphoAccess® SIGMA Overview

The MorphoAccess® SIGMA terminal has a simple and ergonomic man-machine interface designed for access control and Time & Attendance, with fingerprint recognition, contactless card authentication and PIN authentication options.



Indoor & Weather Resistant (WR) Checklist

Product packaging checklist:

QTY	ITEM
1	MorphoAccess® SIGMA terminal
1	Micro SD card installed in the terminal
1	Wall Mount Plate
1	Battery 
1	POE module 
1	Protection Accessory (WR* product only)
1	Flat screw driver 0.4 x 2.0
1	Quick Installation Guide
1	WEEE notice

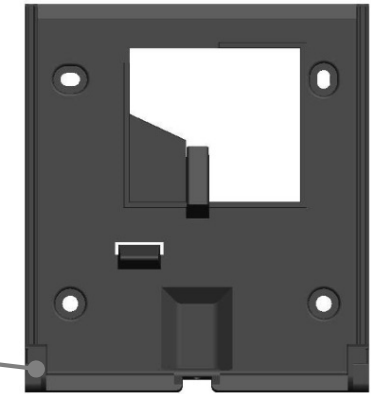

Micro SD card must be installed in the terminal at start up (storage area for internal database and terminal logs)

Micro SD card replacement:

- Class 10 or higher, 1GB min, 32GB max
- Formatted by the terminal. Windows® PC may damage the content of the card and make it inoperative.
- Use only Brand Name cards. No name card may have lower performances or lower life time.

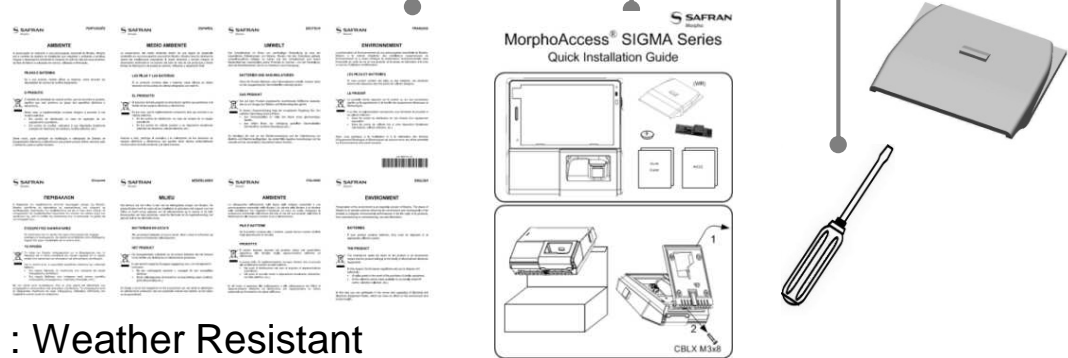

*WR : Weather Resistant

Electronic documentation is provided in Adobe® Acrobat® format (PDF). Adobe® Acrobat® Reader is available at <http://www.adobe.com>.

Step one : overview

MorphoAccess® SIGMA Series

The MorphoAccess® SIGMA Series contains the following product variants:

Product designation	Biometrics (Fingerprint)	Contactless Smart card reader		Prox®	Water Resistant (*)
		iCLASS®	MIFARE® DESFire® NFC		
MA SIGMA	✓				
MA SIGMA WR	✓				✓
MA SIGMA iCLASS	✓	✓			
MA SIGMA iClass WR	✓	✓			✓
MA SIGMA Multi	✓		✓		
MA SIGMA Multi WR	✓		✓		✓
MA SIGMA Prox	✓			✓	
MA SIGMA Prox WR	✓			✓	✓

MA stands for MorphoAccess® and WR stands for Water Resistant

(*) WR units must be installed according to installation guidelines on *Quick Installation Guide*

MorphoAccess® SIGMA terminal implementation

To secure an access, Morpho recommends installing the MorphoAccess® SIGMA Series terminal as a part of a typical Access Control system, this consists of the components described below.

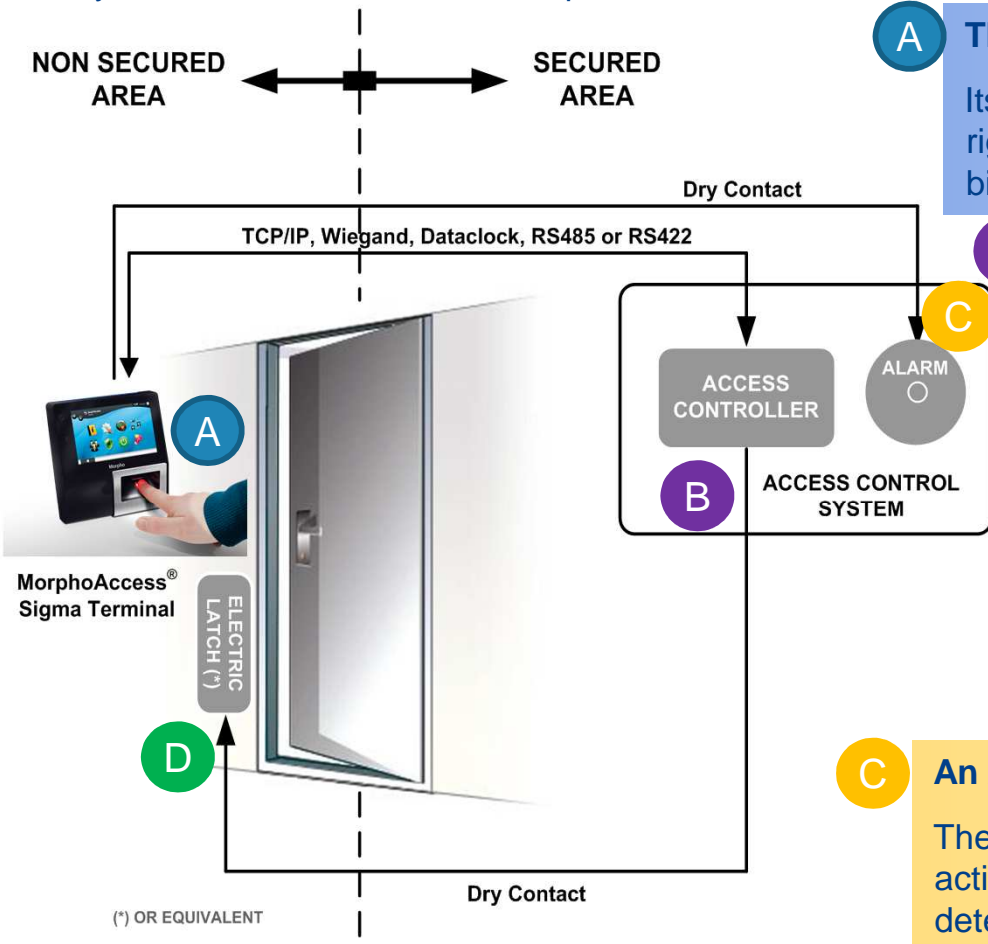

A The MorphoAccess® SIGMA Series terminal

Its role is to process the access request from the user. It performs access right checks using one-to-many biometric identification or one-to-one biometric verification, and/or RF card authentication, and/or PIN check.

B An Access Controller (3rd party product)

The MorphoAccess® terminal interfaces with an Access Controller (using TCP/IP, Wiegand, Data Clock or RS485 protocol):

- ➔ After user's access rights checks, the MorphoAccess® terminal sends the result to the Access Controller (this message contains at least the User ID)
- ➔ The Access Controller performs additional checks, and returns the final decision (access granted/denied) to the MorphoAccess® terminal (which displays the result to the user), and to the door controller which opens the door (if the access has been granted).

C An Alarm (3rd party product)

The MorphoAccess® terminal sends a message to the Access Controller, to activate the Alarm as soon as a malicious activity such as tamper or pulling, is detected.

D A Door Electric Latch or equivalent such Deadbolt, Door Strike or Magnetic Lock (3rd party product)

The Access Controller sends a command to activate the latch if the access is granted (i.e. if the individual's User ID is listed in the Controller White List). Control of the latch is made through a dry contact..

MorphoAccess® SIGMA Access Control Modes

The terminal can be configured in one of the modes described in the table below

	Identification	Authentication	Multifactor	Proxy
Access control application	Application that runs on the terminal when it starts.	Application that runs on the terminal when it starts.	Application that runs on the terminal when it starts.	Remote application that controls the terminal through network commands
Access control triggering event	A user places a finger on the biometric sensor.	A user places a contactless card in front of the reader (1)	Both Identification and Authentication triggers are enabled.	Triggering events are selected by the remote application
Biometric check (if enabled)	The user's captured fingerprint template is matched against all fingerprint templates in the terminal database (3)	The user's captured fingerprint template is matched against his reference fingerprint templates (2)	As per Identification or Authentication, depending on the triggering event	Selected by the remote application
Decision to display result signal to user	By Identification standalone application	By Authentication standalone application	By running standalone application	By remote application

(1) or the user enter their Identifier on the keypad, or a Wiegand frame is received from an external device

(2) stored on the contactless card or in the user record in the terminal's local database

(3) There is no fingerprint image stored in the terminal, but only points of interest (minutiae) of each fingerprint

Deployment Environments

Operating temperature	-20° to + 60 ° C (- 4° to 140° F)
Operating humidity	10 % < RH < 80 % (non condensing)
Storage temperature	- 25° to + 70 ° C (-13° to 158° F)
Storage humidity	5% < RH < 95 %
IP code	IP65 rated for WR(*) products (once wall-mounted)

(*) **WR units must be installed according to installation guidelines on *Quick Installation Guide***

General precautions

- Do not expose the terminal to extreme temperatures.
- When the environment is very dry, avoid synthetic carpeting near the MorphoAccess® SIGMA terminal, to reduce the risk of unwanted electrostatic discharge.

Areas containing combustibles

- Do not install the terminal in the vicinity of gas stations or any other installation containing flammable or combustible gases or materials. The terminal is not designed to be intrinsically safe.

The terminal should be installed in controlled lighting conditions

- Avoid biometric sensor exposure to a blinking light
- Avoid direct exposure of the biometric sensor to sunlight or to UV lights.

Wiring Overview

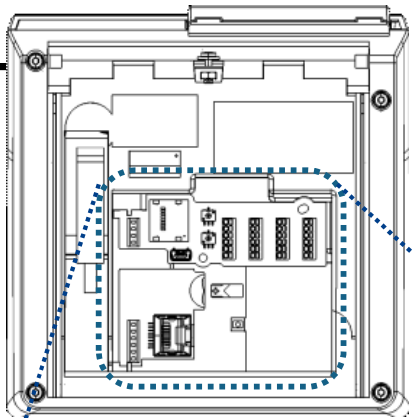

Power supply from electrical source shall be switched off before starting the installation.

Before proceeding, make sure that the person in charge of installation and connections, is properly connected to earth, in order to prevent Electrostatic Discharges (ESD).

All connections of the terminal are of SELV (Safety Electrical Low Voltage) type.

Connection: Insert cable in the round hole of the block connector.

Disconnection: Insert flat screw driver (0.4x2.0max) in rectangular hole and pull the wire.

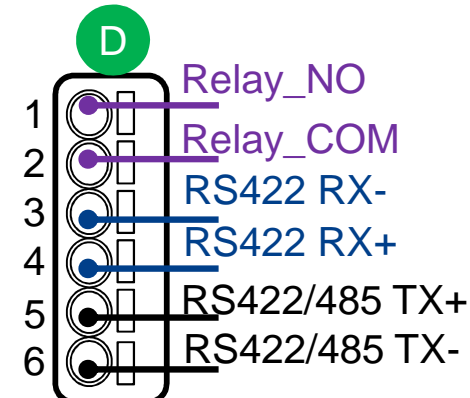
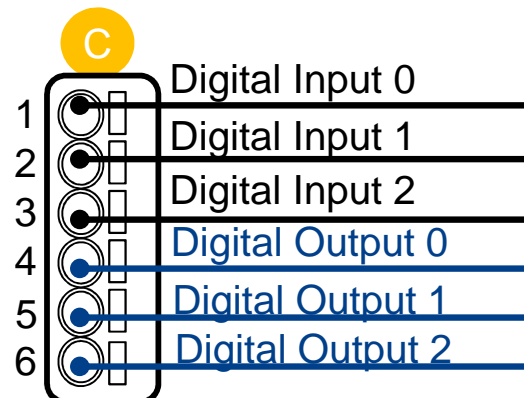
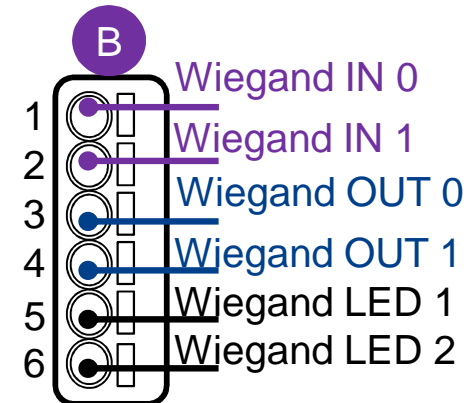
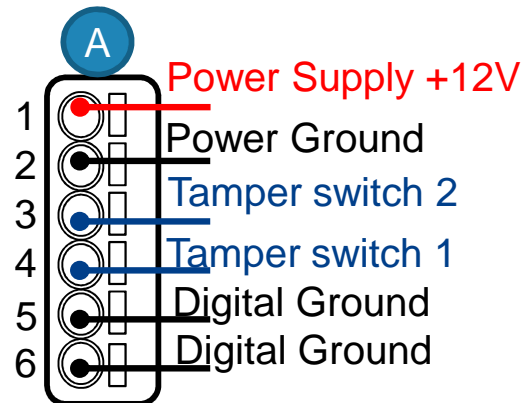
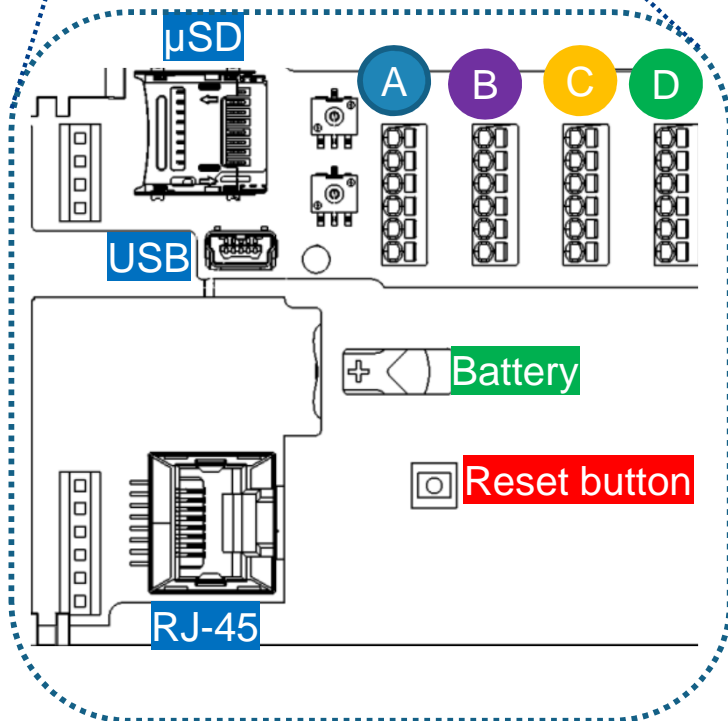

Step two : wiring

Power Wiring

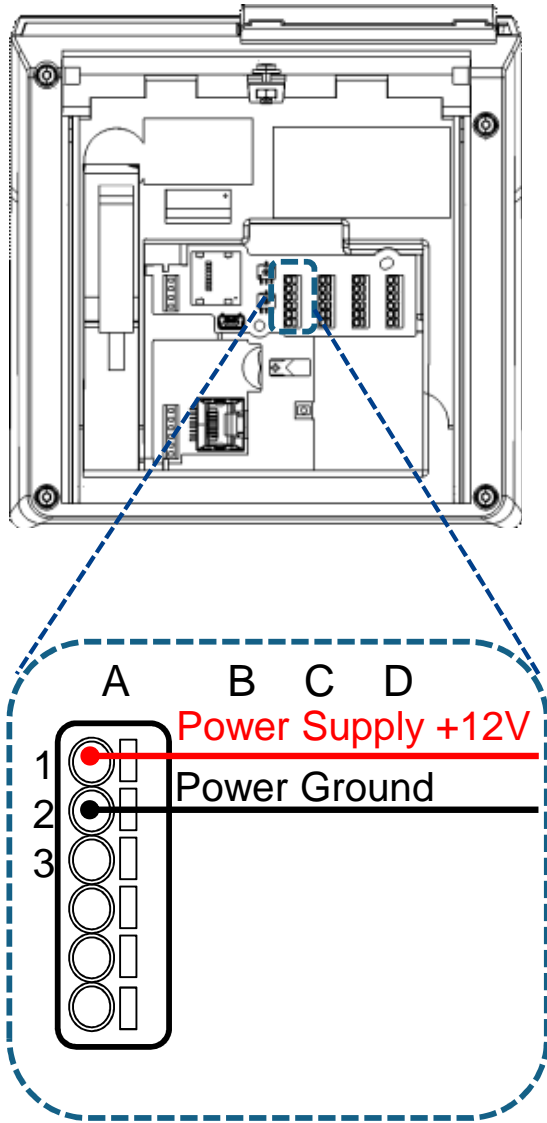

External Power Supply: 12-24 Volts (regulated and filtered) 1 Amp min @ 12V, CEE/EEC EN60950 standard compliant. A 12 Volts power supply compliant with SIA's Wiegand standard will also be suitable. If sharing power between devices, each unit must receive 1A (e.g. two units would require a 12vDC, 2A supply)

A battery backup or uninterruptible power supply (UPS) with built-in surge protection is recommended.

WARNING: Under powering may cause memory and data corruption; over powering may cause hardware damage. Both of these situations will void the warranty



Inversion of +12V and GND will damage the product.

Morpho recommends using a gauge AWG20 for 12V power supply.

The voltage measured on the product block connector of the terminal must be equal to 12V-24V (-15% / +10%).

The table below, shows the maximum voltage drop between the power source and the terminal, depending on the length of the cable.

Gauge AWG	Diameter (mm)	Maximum drop voltage (V)		
		at 1m	at 5m	at 10m
20	0.81	0.03	0.17	0.33
22	0.64	0.05	0.26	0.53
24	0.51	0.08	0.42	0.84

Power Over Ethernet & Battery

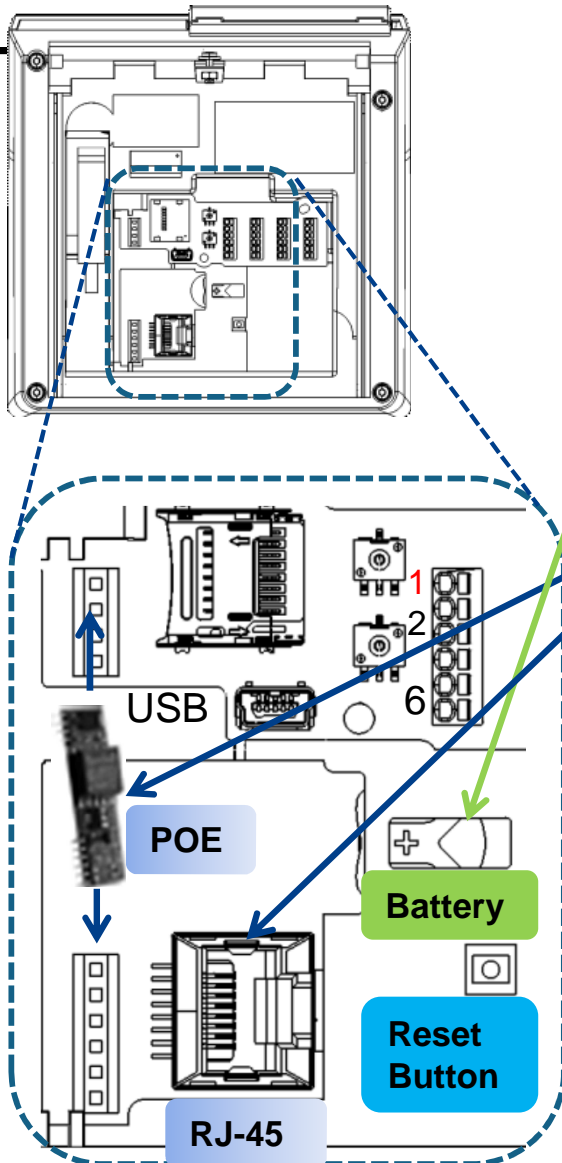

Battery

- Installation : the engraved side, the positive side (+), must face upwards.
- protects the date and time in case of power failure or switch off
- lifetime is limited : at least 350 hours at 25° C, when power is off:
- must be changed after a long power cut or after several shorter power cuts.
- Remove and store the battery if the terminal will be unpowered for a long period of time

Power Over Ethernet (POE): power can be provided through RJ-45 connector using a PSE (Power Sourcing Equipment) IEEE 802.3af or IEEE802.3at type 1 compliant.

This feature requires a specific electronic card plugged at the rear of the product.

Warning : after use, the temperature of the POE module may be high: after power cut off, wait 5mn before working on connectors area.

PoE Injector Specs

- Output Voltage: -48VDC
- Output Current: 0.32A
- Power: 15.36W

Reset Button : performs a hardware reset of the terminal (one power down, power up cycle). No data is lost and the settings are kept if the battery is installed and has charge.

RS-485 Communication

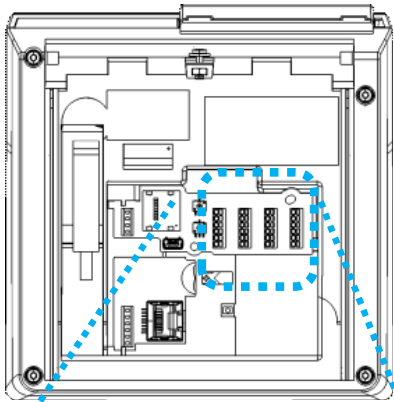

RS-232
from the
Com Port

RS-232 to
RS-485
converter

RS-485 to
1200m (4000ft)



For RS-485 installations, the cable should be run in a daisy-chain configuration (i.e. converter > position 1 > position 2 > position 3, etc.).

Choose a RS-232 to RS-485 converter that supports Sense Data to switch from Send to Receive mode.

Use CAT-5 UTP (or better) cable (shielded recommended) with a impedance of 120 Ω . AWG 24 should be the minimum wire gauge used.

Choose one twisted pair of conductors to use for RS-485 TDA/TX+ (D-5 wire) and RS-485 TDB/TX- (D-6 wire). Another conductor should be used for Signal Ground (A-5 or A-6 wires) .

A maximum of 31 devices may be installed on the same line.

The maximum total cable length is 4000 ft. (1200m).

The cable must be dedicated to this installation and not used for any other purpose

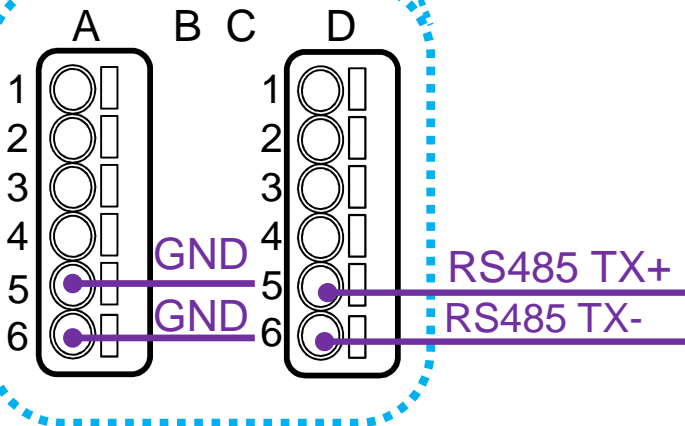

Step three : communications

RS-422 Communication

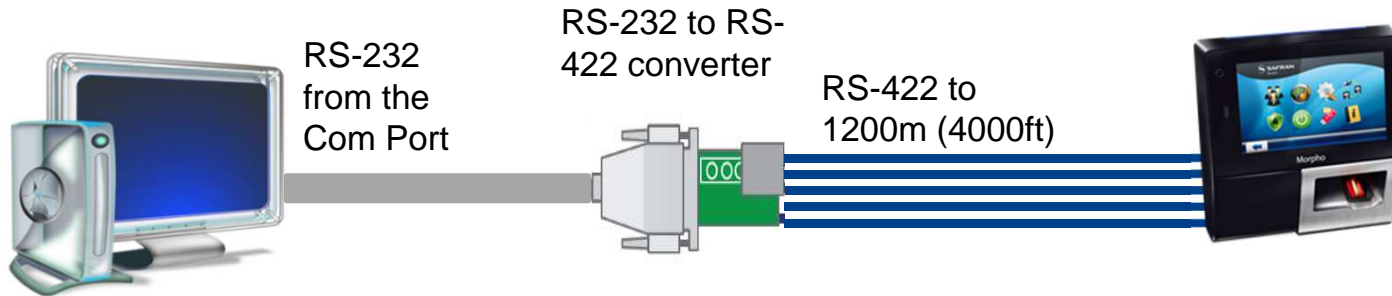
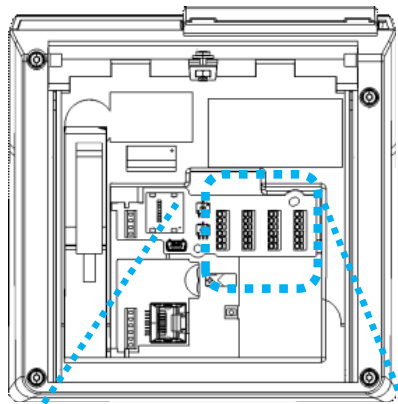

For RS-422 installations, the cable should be run in a point to point configuration (i.e. PC > converter > terminal)

Use CAT-5 UTP (or better) cable (shielded recommended) with a impedance of 120 Ω . AWG 24 should be the minimum wire gauge used.

Choose one twisted pair of conductors to use for RS-422 TDA/TX+ (D-5 wire) and RS-422 TDB/TX- (D-6 wire).

Choose one twisted pair of conductors to use for RS-422 RDA/RX- (D-3 wire) and RS-422 RDB/TX+ (D-4 wire).

Another conductor should be used for Signal Ground (A-5 or A-6 wires).

 The maximum total cable length is 4000 ft. (1200m).

The cable must be dedicated to this installation and not used for any other purpose

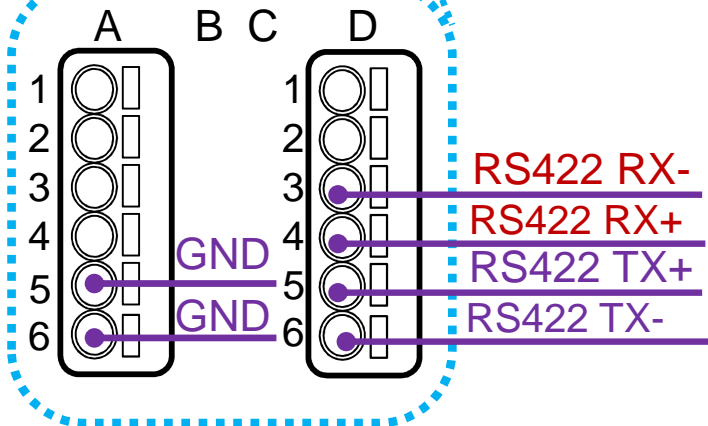

RS422 RX-
RS422 RX+
RS422 TX+
RS422 TX-
GND
GND

Ethernet and Wireless LAN

RJ-45 Ethernet connection (recommended)

- Ethernet connection to the terminal is made through a standard RJ-45 connector on the back of the terminal.
- Use a category 5 shielding cable (120 Ohms) or better. It is strongly recommended to insert a repeater unit every 90m.
- MorphoAccess® terminals are DHCP enabled by default

Terminal Block Ethernet connection

- Extreme care must be taken while connecting Ethernet wire to the block board since low quality connection may strongly impact Ethernet signal sensibility.
- Connect Rx+ and Rx- with the same twisted-pair wire (and to do the same with Tx+/Tx- and the other twisted-pair wire).

WLAN option

This option is available only with Wi-Fi™ dongle (and adaptation cable) delivered by Morpho (kit reference 293658530), **and requires the terminal be powered by an external AC/DC 12V to 24V power supply (the POE feature doesn't provide enough power for the terminal and the dongle).** Morpho Wi-Fi™ dongle supports 802.11b and 802.11g standards, WEP Open, WPA and WPA2.



The Wi-Fi™ dongle shall not be exposed to temperatures exceeding 50° C (thermal dissipation). The Wi-Fi™ dongle shall be installed outside the product (separate area shall be reserved in the wall).



Wiegand Communication

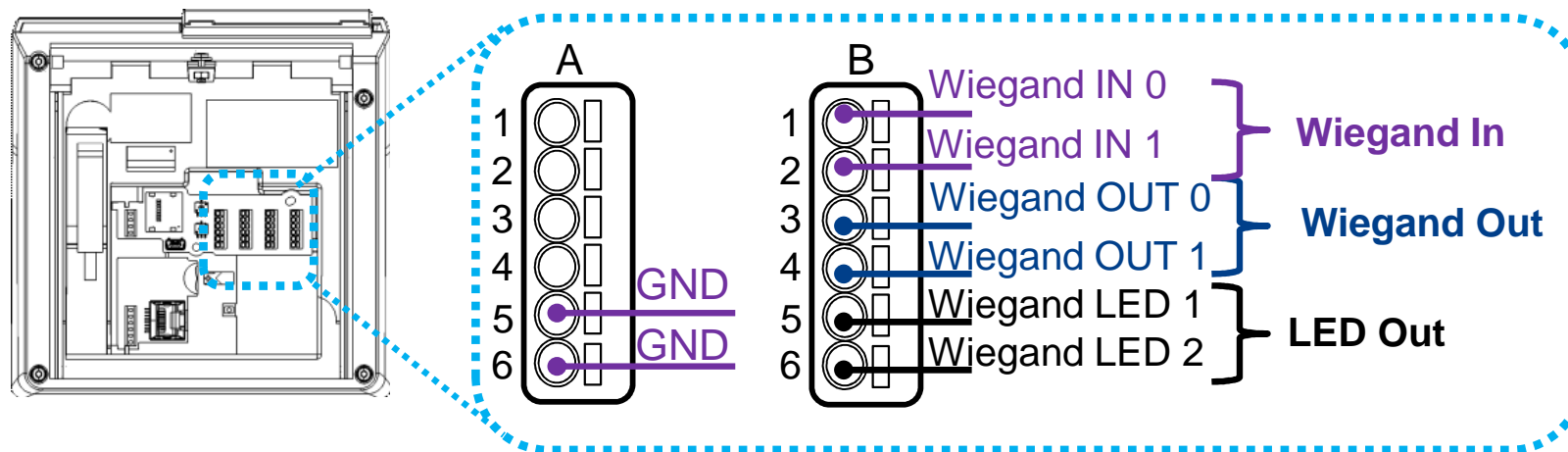

Three-conductor wire (shielded recommended) is required for Data 0, Data 1, and WGND.

Use 18-22 AWG cable in a homerun configuration from each unit to the Access Control Panel (ACP).

- Connect **WIEGAND_OUT0** (B-3 Wire) to ACP Data 0,
- Connect **WIEGAND_OUT1** (B-4 Wire) to ACP Data 1,
- Connect **WIEGAND_GND** (A-5 or A-6 Wire) to ACP reader common (0vDC).

For 18 AWG, the maximum cable distance is 500 ft. (150m); for 20 AWG, the maximum is 300 ft. (90m); for 22 AWG, the maximum is 200 ft. (60m).

Electrical interface conforms to the Security Industry Association's Wiegand standard March 1995, and it is 5V TTL compatible.

Wiegand Communication (continued)

Important

By default, the Wiegand output format is not enabled. Wiegand output must be configured before connecting to the ACP.

Note

On installation, the system administrator will be prompted to select either a pre-existing Wiegand frame format or create a custom format, and upload it to the unit before the first use.

Data Clock

The Wiegand port also supports the Clock & Data protocol. The wiring is described below.

Example Format Information

Type: **Standard 26-bit**

- Alt Site Code and Fail Site Code Range: **0-255**
- Template ID Number Range: **1-65535**
- Extended ID Number Range: **N/A**
- ID Start Bit: 9
- Length of ID: 16
- Site Code Start bit: 1
- Length of Site Code: 8
- Start Bit length : 0

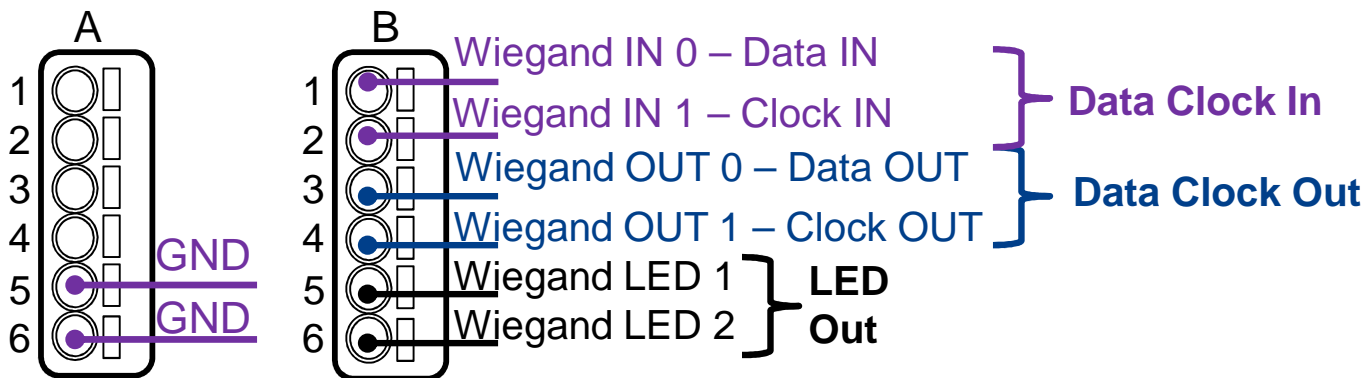

SINGLE DOOR ACCESS CONTROL (SDAC)

Single Door Access Control (SDAC) wiring sample : with Push Button

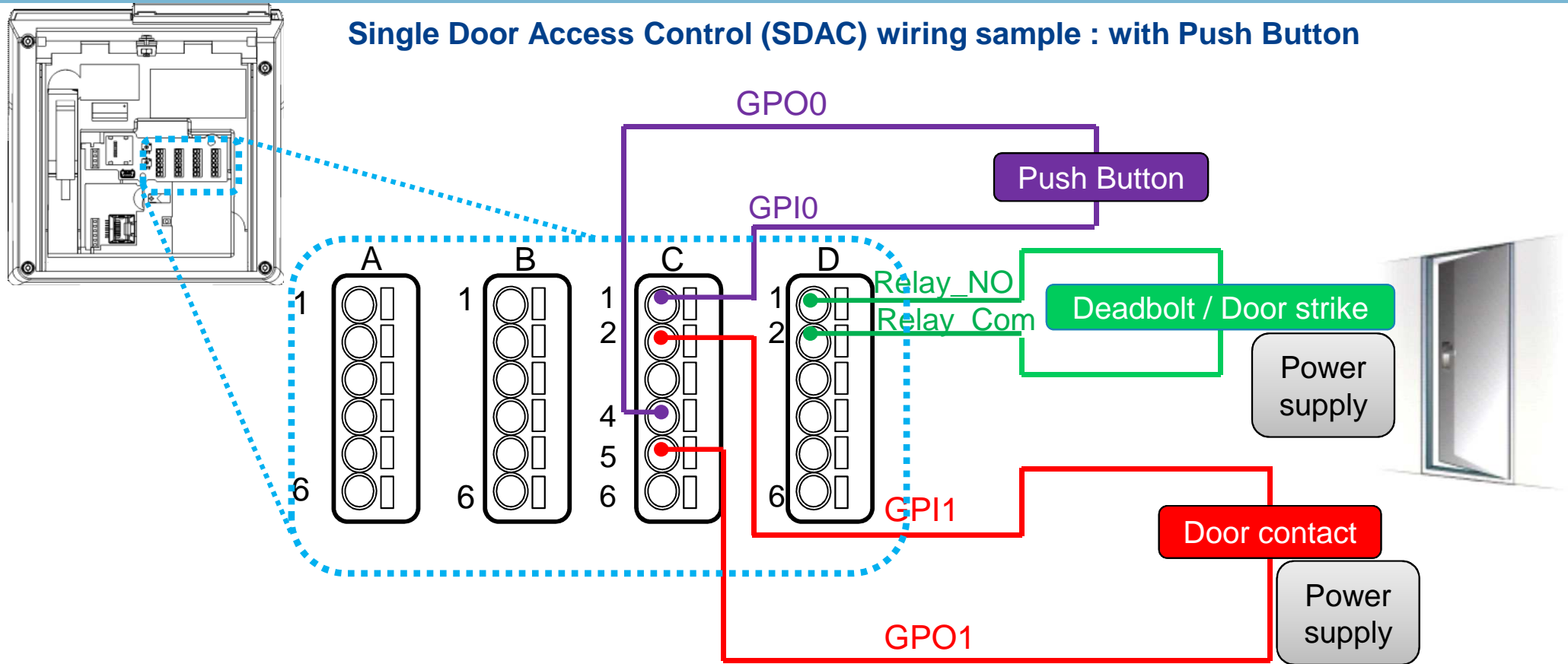

Warning

- Please check next page for important information about internal relay rating
- If door contact is not used, GPI1 (C-2) and GPO1 (C-5) shall be connected together
- Power supply from electrical source shall be switched off before starting the installation.

Step four: ACP or SDAC

Internal Relay Wiring (Normally open)

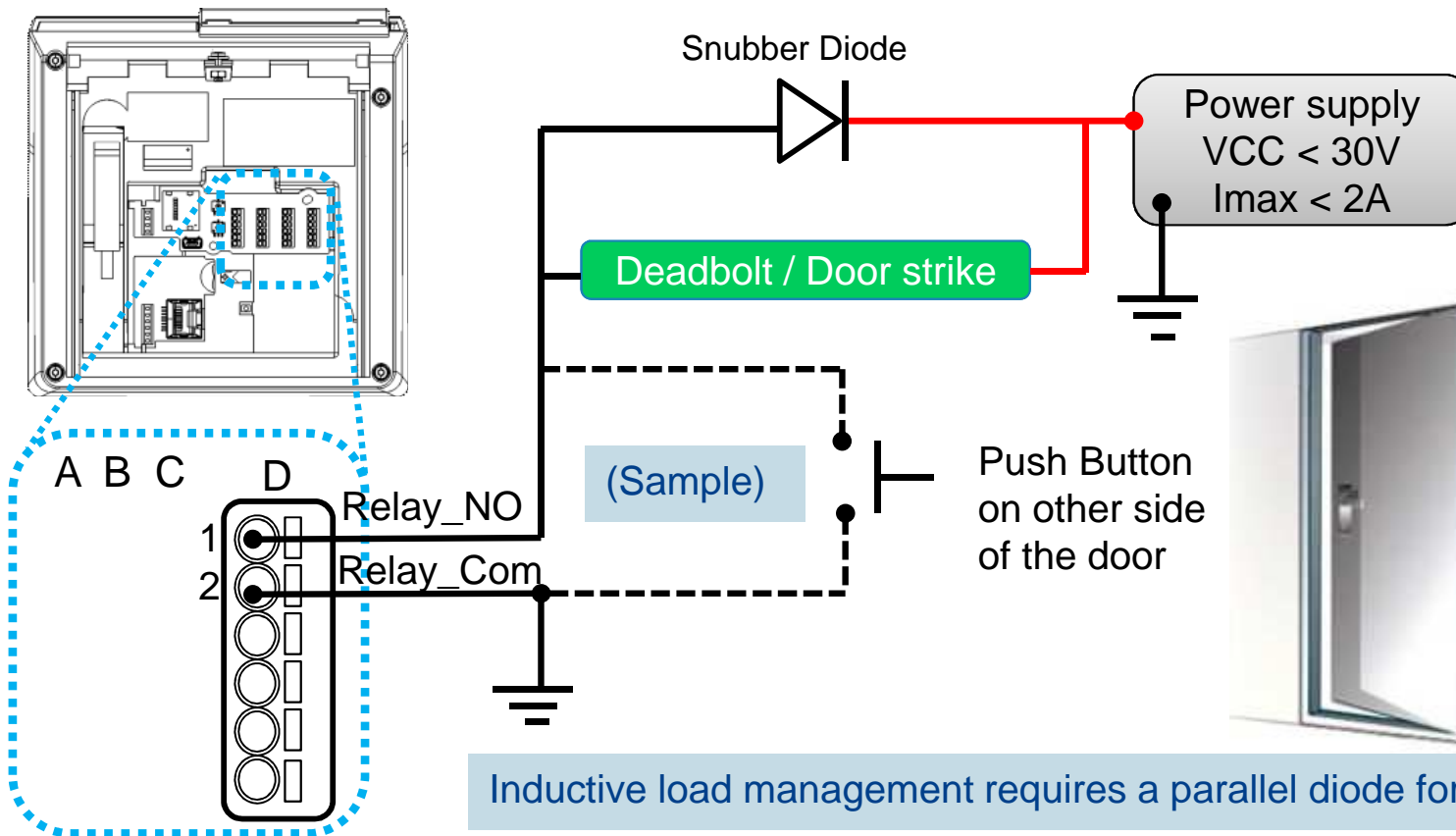

Warning

This applies only for small or stand-alone applications where access control panels are not available.

In this mode it is strongly recommended to monitor the Tamper Detection of the device

Relay mode can be changed to “normally close” instead of “normally closed” (default)

Inductive load management requires a parallel diode for a better contact lifetime.

Warning

- The internal relay is limited to a maximum current of 2A @ 30V. If the deadbolt / door strike draws more than 2A, damage to the device may occur. If the deadbolt / door strike load exceeds 2A, an external relay must be used.
- The internal relay is designed for 100.000 cycles. If more cycles are needed, an external relay driven by GPO must be used.

Local Administration - First Boot Assistant

The First Boot Assistant (FBA) helps the administrator to configure all the devices fundamental settings.

It is automatically launched at first terminal startup, but can also be launched on demand, though administration menu (i.e. to reinitialize terminal main settings)



The battery must be installed to prevent real time clock loss on power off or power failure

Main settings managed by FBA

Date & Time Configuration: date & time, time zone

Language Configuration: user interface language selection,

Trigger Event: select event(s) to be processed as an access request by a user

Network Configuration: LAN or WLAN parameters

Recognition Mode: identification mode activation.

Protocol Configuration: select communication protocol : Bioscrypt 4G terminals, MA 500 and J Series (MA2G), or MorphoAccess SIGMA (MA5G)

Password Configuration: terminal administration password modification

First Boot Configuration Storage Type: select either temporary (i.e. for a short duration test, reboot will restore previous values) or permanent storage (applies to normal operation, new settings remains after reboot) of the setting modified by FBA.

Local Administration – Using Touch Screen Menu



Frequently used icons



Exit or Go Home



Validation or confirmation



Back (and Cancel)



Cancel or refuse

For security reasons, it is highly recommended to change the devices default password to a custom password.



User management



Multimedia management



Terminal settings



Communication settings



Security



Restart Start/Stop



USB key management



Information about terminal

Step five: Administration

Administration with MorphoBioToolBox application

The MorphoAccess® SIGMA Series terminal can be configured using a dedicated (Windows) application : **MorphoBioToolBox** Please note that this application has an embedded User Guide (Help menu).

North and South America :
E-mail cscenter@morpho.com with your name, phone number, serial number of your MASIGMA and **“Please Send Link for MBTB”** in the subject of your e-mail. A link to download the software will be e-mailed to you.
Other countries : please contact your sales representative.



Terminal administration with MorphoBioToolBox (MBTB) application

A screenshot of the MorphoBioToolBox (MBTB) application interface. The window title is "SAFRAN Morpho" and it has a menu bar with "File", "Options", and "Help". The main area is titled "Connection" and contains a "Terminal Type" dropdown menu set to "MA Sigma". Below this is a "Connection information" section with radio buttons for "TCP / IP" (selected) and "Serial". Under "TCP / IP", there are options for "Address type" (IP4 selected, IP6 unselected), an "Address" field, a "Port" field set to "11010", and a "Timeout" field set to "0" seconds. There are also checkboxes for "Use SSL/TLS" and "Use Socks". Below these are fields for "Terminal CA certificate path", "Client certificate path", and "Client certificate password", each with a "Browse" button. A "Connection" button is at the bottom of the form. On the right side of the window, there is a vertical sidebar labeled "Recent Terminals". At the bottom of the window, there is a "MBTB Logs" section with buttons for "Erase logs" and "Export". The log entries show successful loads of various plugins: "11:34:52 - INFO - Load successful;MBTB.Plugins.RebootFeature", "11:34:52 - INFO - Load successful;MBTB.Plugins.PingFeature", "11:34:52 - INFO - Load successful;MBTB.Plugins.PasswordConfigurationTabFeature", "11:34:52 - INFO - Load successful;MBTB.Plugins.PassphraseConfigurationTabFeature", and "11:34:52 - INFO - Load successful;MBTB.Plugins.JobCodesTabFeature". A large red "Sample" watermark is overlaid on the screenshot.

Step five: Administration

Administration with Embedded Web Server

The terminals embedded Web server enables easy configuration of the devices using a web browser on a Desktop PC, Laptop, Tablet or smart phone.



The connection to the embedded Webserver, through LAN or WLAN, requires the terminals IP address (available with local administration) and terminals password (same as local administration password specified in previous page).

By default, webserver is disabled, then if necessary it must be enabled using local administration before use.

Terminal administration with a standard web browser

Welcome Admin | [Contact Us](#) | [Logout](#)

SAFRAN Morpho

- Device Settings
 - General
 - Tamper
 - GPIO
 - SDAC
 - Time and Attendance
 - Transaction Log
 - Biometric
 - Communication
 - Controller Feedback
 - Datetime
 - Wiegand
 - User Control Configurations
 - Threat Level
 - Event Configurations
 - Access Schedules
 - Holiday Schedules
 - Door Open Schedules
 - Complete Configuration (Advanced users only)

Terminal

Commercial Name	MA SIGMA Multi WR
Descriptive Name	MORPHOACCESS
Serial Number	1336SMS0000245
Packaged Part Number	293638885
License Name	MIMA;VERIF;BCL;MA_PAC;MA_TA
License Identifier	293645695-13212510235-03674484597
Firmware Version	MA1.0.8
Sensor Part Number	293625995
Sensor Serial Number	1330S033230
Product Specific Part Number	293638885

MAC Address

Ethernet	00:24:ae:01:5e:23
Wi-Fi	
3G	

Users' Information

All Users / Maximum Capacity	1 / 250000
Total Users Enrolled / Maximum Capacity	1 / 3000
VIP Users / Maximum Capacity	0 / 100
White-list Users / Maximum Capacity	1 / 250000

Software for Terminal Remote Administration

- **MorphoAccess® SIGMA Series terminals are fully compatible with:**
 - MorphoManager application(version 1.0 or later)

- **When Legacy Morpho mode enabled, the terminal is compatible with:**
 - MEMS (version 7.3.1 or later),
 - The limitations in Morpho Legacy mode are described in the following document:
 - MorphoAccess® SIGMA Series Release Note - Legacy Morpho limitations

- **When Legacy L1 mode is enabled, the terminal is compatible with:**
 - SecureAdmin (version v4.1.19.0.0.a10.0 or later),
 - The limitations in L1 Legacy mode are described in the following document:
 - MorphoAccess® SIGMA Series Release Note - Legacy L1 limitations

Local Enrolment Process on MorphoAccess® SIGMA

A new user can easily be added by using the administration menu of the MorphoAccess® SIGMA terminal.

This “local enrolment” is recommended only for small or stand alone installations or testing purposes. For professional systems enrolment should be performed remotely with an enrolment station, which is a PC with a dedicated application such as MorphoManager.

This menu allows a user’s record to be added in the local database, with the option of creating a user RF card, with the user’s reference data.

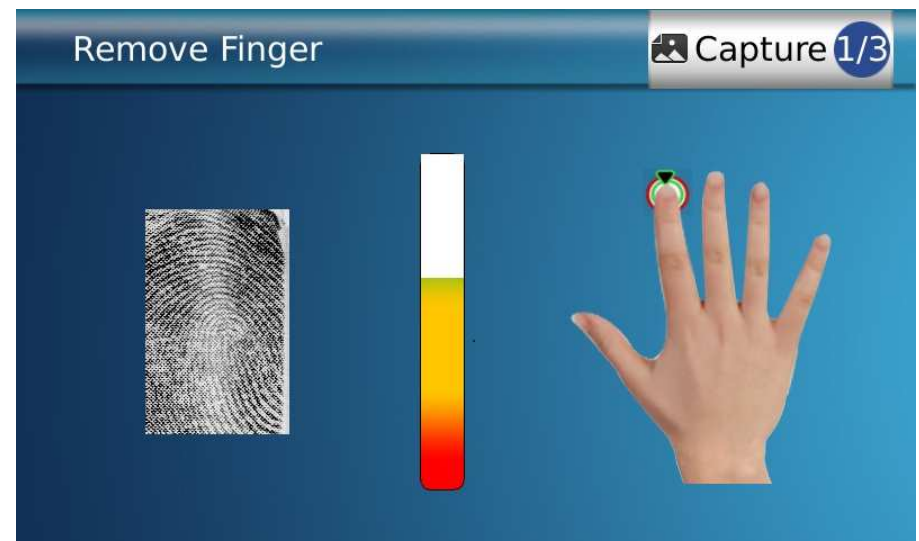

Enrolment gathering user’s data listed below (depending on features enabled in the terminal) :

- User’s first name and last name
- User’s fingerprints (for biometric check)
- User’s administration rights (none, settings, database)
- User’s PIN (for PIN check)
- User’s duress fingerprint
- User’s access schedule and holiday schedule
- User’s dynamic message setting
- User’s record expiry date
- User to include in white list or in VIP list
- User specific access rules definition



Step seven: capture basics

Fingerprint Capture Basics 1/3

Region of Interest	Recommended Fingers	Acquisition troubleshooting
 <p>The biometric sensor is designed to capture the most useful area of the fingerprint, which is usually at the centre of the finger tip, as shown on the figure above.</p>	 <p>The sensor can capture any finger, but we recommend to :</p> <ul style="list-style-type: none"> • use Fore finger / Index as 1st choice • use middle finger as 2nd choice • use ring finger as alternative 2nd choice (3rd choice) • avoid little finger (poor fingerprint) • avoid thumb (best accuracy but ergonomically more difficult to use) 	<p>Finger to capture</p> <ul style="list-style-type: none"> ➤ the fingerprint area must be free of any occlusion (if not, select another finger to capture, such as the 2nd enrolled finger in case of authentication or identification) ➤ do not press or tense finger to avoid blood vessels constriction. <p>Fingerprint image too dark : the finger is probably too moist and/or too dusty</p> <ul style="list-style-type: none"> ➤ too moist : <i>dry the finger</i> ➤ too dusty: <i>clean up the finger</i> <p>Fingerprint image too light : the finger is probably too cold and/or too dry</p> <ul style="list-style-type: none"> ➤ too cold : <i>warm up the finger</i> ➤ too dry : <i>moisten the finger (i.e. with moistening pad) and /or warm it up.</i>

For handling large scale enrollments please contact your Morpho representative for training and services options

Step seven: capture basics

Fingerprint Capture Basics 2/3

Ideal Finger Position

Finger Height

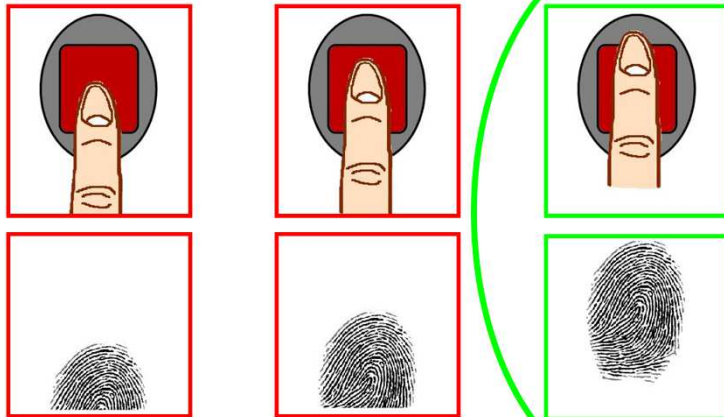

Incorrect Position: ⚠

- Do not place the finger tip :
 - on the bottom of the sensor,
 - or in the middle of the sensor

Correct Position:

- Align centre of finger tip with sensor centre

Finger Angle

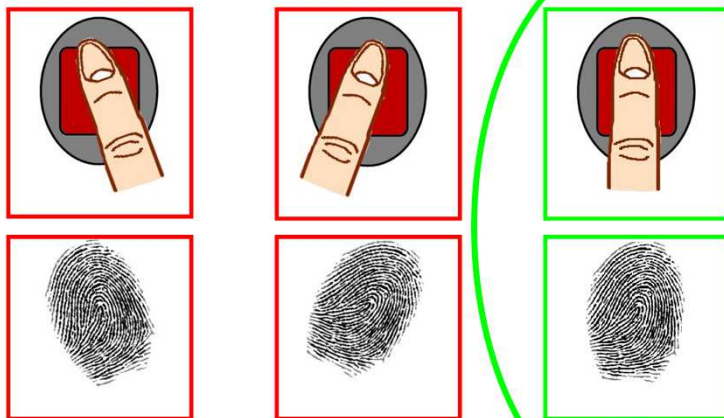

Incorrect Position: ⚠

- Do not tilt the finger to the right or left side of the sensor

Correct Position:

- The finger must be parallel to sensor sides

IDEAL POSITION

Fingerprint Capture Basics 3/3

Ideal Finger Position

Finger Inclination

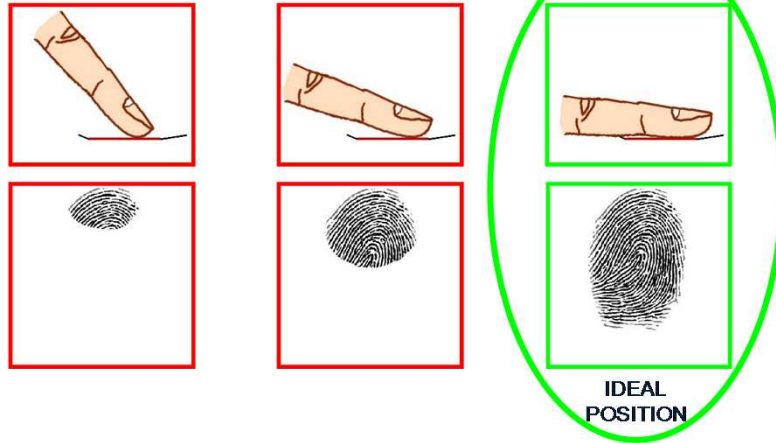

Incorrect Position:

- Do not leave the finger in the air
- Do not bend finger upward or downward

Correct Position:

- Finger is parallel to sensor surface

Finger rotation

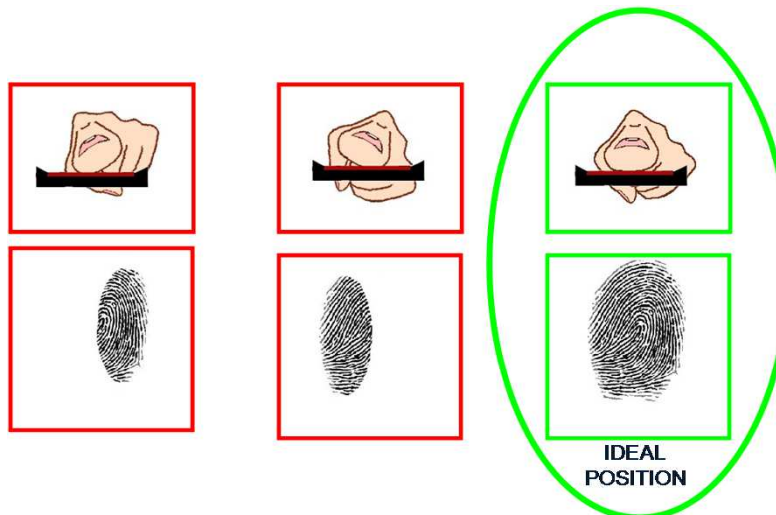

Incorrect Position:

- Do not roll finger

Correct Position:

- Finger is parallel to surface sensor

Contactless Card Position – PIN input

Contactless Card Position



This action is required once during the user enrolment process (generation / encoding of a user RF card), and at each authentication.



Place user's RF card in front of embedded contactless card reader which is located behind the contactless logo.

The authentication process is initiated by the detection of a user card by the (optional) contactless card reader.

The terminal reads the user data stored in the card (at least the User ID), and starts the authentication process, as defined by the terminal settings

Input PIN



When defined by terminal settings, the user is required to enter his PIN code, once during enrolment process, and at each authentication (in addition or instead of biometric check).

The PIN code is entered using a numeric keypad displayed on the LCD touch screen.

Recommendations

The manufacturer cannot be held responsible in case of non-compliance with the following recommendations or incorrect use of the terminal.

Repair and Accessories

- Do not attempt to repair the MorphoAccess® SIGMA Series terminal yourself. The manufacturer cannot be held responsible for any damage/accident that may result from attempts to repair components. Any work carried out by non-authorized personnel will void your warranty.
- Only use the terminal with its original accessories. Attempts to use unapproved accessories with your terminal will void your warranty.

Standalone terminals (not connected to a network)

- For terminals used in standalone mode, it is strongly recommended to regularly backup the local database, and at least after significant changes in the database (add, remove or modification of user's records), on a external support such a mass storage key

Micro SD Card

- The micro SD card is linked to the terminal : it shall not be transferred from one product to another.

Date / Time synchronization

- The MorphoAccess® SIGMA Series terminal clock has a +/- 10 ppm typical time deviation at +25° C (roughly +/- 1sec per day). At lower and higher temperature, deviation may be greater (maximum : 8 seconds per 48 hours).
- When the terminal is used for applications requiring high time precision, it is strongly recommended to synchronize the terminal with an external clock.

Cleaning precautions

- A dry cloth should be used to clean the terminal, especially the biometric sensor.
- The use of acid liquids, alcohol or abrasive materials is prohibited.

Firmware release

- To get the best of our technology, we recommend you to download and install the last firmware release (please refer to last page)

Documentation

Documents about installing the terminal

MorphoAccess® SIGMA Series Installation Guide, Ref. 2014_0000000606

This document describes the terminals physical mounting procedure, electrical interfaces and connection procedures.

Documents about administrating / using the terminal

MorphoAccess® SIGMA Series Quick User Guide, Ref. 2014_0000000530

This document gives a quick overview of the product and the basics of configuration and use.

MorphoAccess® SIGMA Series Administration Guide, Ref. 2014_0000002196

This document describes the different functions available on the terminal and the procedures for configuring the terminal. It also contains the full description of all the configuration parameters for the terminal.

MorphoAccess® SIGMA Series Parameters Guide, Ref. 2014_0000000454

This document contains the full description of all the terminal configuration parameters.

Documents for the developer

MorphoAccess® SIGMA Series Host System Interface Specification, Ref. SSE-0000101112

This document describes the commands supported by the MorphoAccess® terminal.

MorphoAccess® SIGMA Series Remote Message Specification, Ref. SSE-0000101111

This document describes the format of messages sent by the terminal to a distant system.

Release note : for each firmware version, a release note is published describing the new features, the supported products, the potential known issues, the upgrade / downgrade limitations, the recommendations, the potential restrictions...

North and South America: you may obtain these document by e-mailing cscenter@morpho.com with your name, phone number, MA SIGMA serial number and "Send Links For MASIGMA Documents" in the subject line.

Other countries: please contact your sales representative.

Notes

Contacts

Technical Support and Hotline

North America

Mail: cscenter@morpho.com

Tel: +1 888 940 7477

South America

Mail: cscenter@morpho.com

Tel: +1 714 575 2973

South Africa

Mail: sec.san.bio.support@morpho.com

Tel: + 27 11 286 5855

India:

Mail: support.morphoindia@morpho.com

Tel: 0120-4699900

Europe and rest of the world:

Mail: hotline.biometrics@morpho.com

Tel: +33 1 58 11 39 19

For the latest firmware, software, document releases, and news, please check our websites :

- **North and South America** : e-mailing cscenter@morpho.com with your name, phone number, MA SIGMA serial number and “Send Links For MASIGMA Documents” in the subject line
- **Other countries** : please visit our web site www.biometric-terminals.com. Morpho partners : to get your log in and password for the private area, please contact your sales representative).

Copyright © 2015, Morpho. All rights reserved.

www.morpho.com

Reproduction in whole or in part in any form or medium without the express written permission of Morpho is prohibited.

The trademarks identified herein are the trademarks of registered trademarks of Morpho, or other third party.

293684580-A

